



**LICENSING ACT 2003
PREMISES LICENCE**

Cyngor Sir **Ceredigion** County Council



s licence number

PRM 0577 (Issued 30/03/2012)

Premises details

Postal address of premises, or if none, ordnance survey map reference or description

**'THE RARE ONE'
LOVESGROVE (SN634811)**

Post town

ABERYSTWYTH

Post code

Telephone number

Where the licence is time limited the dates

FRIDAY 18th of May 2012 from 14:00hrs to 04:00 hrs on Saturday the 19th of May and, from 12:00hrs on Saturday the 19th May through to 04:00hrs on Sunday the 20th May 2012.

Licensable activities authorised by the licence

REGULATED ENTERTAINMENT:

FILMS - Indoors

LIVE MUSIC - Indoors

RECORDED MUSIC – Indoors and Outdoors

PERFORMANCE OF DANCE

ANYTHING OF SIMILAR DESCRIPTION

ENTERTAINMENT FACILITIES:

MAKING MUSIC - Indoors

DANCING - Indoors

ENTERTAINMENT OF A SIMILAR DESCRIPTION TO MAKING MUSIC or

DANCING - Indoors

SALE BY RETAIL OF ALCOHOL – On sales only

LATE NIGHT REFRESHMENT – Indoors and Outdoors

The times the licence authorises the carrying out of licensable activities
REGULATED ENTERTAINMENT:

FILMS

LIVE MUSIC - Indoors

FILMS - Indoors

RECORDED MUSIC – Indoors and outdoors

PERFORMANCE OF DANCE

ANYTHING OF SIMILAR DESCRIPTION

ENTERTAINMENT FACILITIES:

MAKING MUSIC - Indoors

DANCING - Indoors

ENTERTAINMENT OF A SIMILAR DESCRIPTION TO MAKING MUSIC or

DANCING - Indoors

SALE BY RETAIL OF ALCOHOL – On sales only

LATE NIGHT REFRESHMENT – Indoors and Outdoors

ALL ABOVE ACTIVITIES:

FRIDAY 18th of May 2012 from 14:00hrs to 04:00 hrs on Saturday the 19th of May and, from 12:00hrs on Saturday the 19th May through to 04:00hrs on Sunday the 20th May 2012.

Recorded music will be played at the outdoors 'performance space' as described on the site plan. This will terminate at 23:00hrs on 18/05/2012 and 19/05/2012

The opening hours of the premises

FRIDAY 18TH OF MAY 2012 FROM 14:00HRS TO 04:00 HRS ON SATURDAY THE 19TH OF MAY AND, FROM 12:00HRS ON SATURDAY THE 19TH MAY THROUGH TO 04:00HRS ON SUNDAY THE 20TH MAY 2012.

Where the licence authorises supplies of alcohol whether these are on and/or off supplies

ON SALES only

Name, (registered) address, telephone number and email (where relevant) of holder of premises licence

MR RHODRI SHAW

Registered number of holder, for example company number, charity number (where applicable)

Name, address and telephone number of designated premises supervisor where the premises licence authorises the supply of alcohol

TANYA LOUISE MASON

Personal licence number and issuing authority of personal licence held by designated premises supervisor where the premises licence authorises for the supply of alcohol

CER 0747

CEREDIGION COUNTY COUNCIL

Annex 1 - Mandatory conditions

Mandatory conditions where licence authorises supply of alcohol

- (1) No supply of alcohol may be made under the premises licence—
 - (a) at a time when there is no designated premises supervisor in respect of the premises licence, or
 - (b) at a time when the designated premises supervisor does not hold a personal licence or his personal licence is suspended.
- (2) Every supply of alcohol under the premises licence must be made or authorised by a person who holds a personal licence.

Mandatory condition where the premises licence includes a Condition that at specified times one or more individuals must be at the premises to carry out a security activity:

- (1) Each such individual must be licensed by the Security Industry Authority.
- (2) But nothing in (1) above requires such a condition to be imposed—
 - (a) in respect of premises within paragraph 8(3)(a) of Schedule 2 to the Private Security Industry Act 2001 (c. 12) (premises with premises licences authorising plays or films), or
 - (b) in respect of premises in relation to—
 - (i) any occasion mentioned in paragraph 8(3)(b) or (c) of that Schedule (premises being used exclusively by club with club premises certificate, under a temporary event notice authorising plays or films or under a gaming licence), or
 - (ii) any occasion within paragraph 8(3)(d) of that Schedule (occasions prescribed by regulations under that Act).
- (3) For the purposes of this section—
 - (a) “security activity” means an activity to which paragraph 2(1)(a) of that Schedule applies, and
 - (b) paragraph 8(5) of that Schedule (interpretation of references to an occasion) applies as it applies in relation to paragraph 8 of that Schedule.

The Licensing Act 2003 (Mandatory Licensing Conditions) Order 2010

With effect from 6th April 2010

1. (1) The responsible person shall take all reasonable steps to ensure that staff on relevant premises do not carry out, arrange or participate in any irresponsible promotions in relation to the premises.

(2) In this paragraph, an irresponsible promotion means any one or more of the following activities, or substantially similar activities, carried on for the purpose of encouraging the sale or supply of alcohol for consumption on the premises in a manner which carries a significant risk of leading or contributing to crime and disorder, prejudice to public safety, public nuisance, or harm to children –

(a) games or other activities which require or encourage, or are designed to require or encourage, individuals to-

(i) drink a quantity of alcohol within a time limit (other than to drink alcohol sold or supplied on the premises before the cessation of the period in which the responsible person is authorised to sell or supply alcohol), or

(ii) drink as much alcohol as possible (whether within a time limit or otherwise);

(b) provision of unlimited or unspecified quantities of alcohol free or for a fixed or discounted fee to the public or to a group defined by a particular characteristic (other than any promotion or discount available to an individual in respect of alcohol for consumption at a table meal, as defined in section 159 of the Act);

(c) provision of free or discounted alcohol or any other thing as a prize to encourage or reward the purchase and consumption of alcohol over a period of 24 hours or less;

(d) provision of free or discounted alcohol in relation to the viewing on the premises of a sporting event, where that provision is dependent on-

(i) the outcome of a race, competition or other event or process, or

(ii) the likelihood of anything occurring or not occurring;

(e) selling or supplying alcohol in association with promotional posters or flyers on, or in the vicinity of, the premises which can reasonably be considered to condone, encourage or glamorise anti-social behaviour or to refer to the effects of drunkenness in any favourable manner.

2. The responsible person shall ensure that no alcohol is dispensed directly by one person into the mouth of another (other than where that other person is unable to drink without assistance by reason of a disability).

3. The responsible person shall ensure that free tap water is provided on request to customers where it is reasonably available.

With effect from 1st October 2010

4. (1) The premises licence holder or club premises certificate holder shall ensure that an age verification policy applies to the premises in relation to the sale or supply of alcohol.

(2) The policy must require individuals who appear to the responsible person to be under 18 years of age (or such older age as may be specified in the policy) to produce on request, before being served alcohol, identification bearing their photograph, date of birth and a holographic mark.

5. The responsible person shall ensure that –

(a) where any of the following alcoholic drinks is sold or supplied for consumption on the premises (other than alcoholic drinks sold or supplied having been made up in advance ready for sale or supply in a securely closed container) it is available to customers in the following measures –

(i) beer or cider: ½ pint

(ii) gin, rum, vodka or whisky: 25ml or 35ml; and

(iii) still wine in a glass: 125ml; and

(b) customers are made aware of the availability of these measures.

Annex 2 - Conditions consistent with the operating Schedule

a) General

The Rare One as an event is now in its 9th year of operation. We've held numerous events over the years at local venues including Aberystwyth Arts Centre, Pafiliwn Bont, Nanteos mansion and of course last year's one day event at the Lovesgrove site. I work in the events industry on a daily basis and am familiar with health and safety and licensing issues related to live music events, however I have taken the initiative to employ a Health and Safety consultant Donald Sinclair, to ensure everything is in place

The Rare One is a live music event geared at an audience of all ages (not only students) with a mixture of all genres of music. We intend to have 4 stages at this event, and an outdoor "Performance Space" including comedy and a mixture of live bands and DJ's, we also intend on having a small bar selling alcohol in each marquee including a beer tent. Please see below how I intend to promote the four licensing objectives. a mixture of live bands and DJ's. We also intend on having a small bar selling alcohol in each marquee. Please see below how I intend to promote the four licensing objectives.

b) The prevention of crime and disorder

1. The event will have a zero tolerance policy to drugs
2. The site will have a perimeter fence patrolled by SIA licensed security guards
3. We will supply 2 x SIA licensed security personnel for the first 100 patrons, another 1 x SIA licensed security personnel will be supplied for every 100 patrons there after.
4. The event will have a strict 18+ years entrance policy to avoid underage drinking.
5. All bar staff will be briefed to check for ID on all patrons looking under the age of 21. Only a valid passport or driving licence will be accepted as proof of age.
6. Alcohol will not be served to anybody seen to be intoxicated.
7. Any violence will result in eviction.

c) Public safety

1. The site will be lit by appropriate street lighting on both the entrance to the site and the exit. The car park and the site itself will also be lit appropriately.
2. All marquees will have appropriate fire exit signage and appropriate fire extinguishers.
3. The security team will be monitoring the capacity of each venue/marquee as not to exceed the regulated legal capacity for fire safety reasons.
4. Event stewards will direct cars into car park and direct patrons to site.
5. There will be a shuttle bus running from site to Aberystwyth to avoid the temptation of drink driving.

6. There will be camping facilities to avoid the temptation of drink driving.
7. In the event of a fire, event stewards and security will direct attendees to the fire muster point while emergency services deal with the incident appropriately.
8. There will be a 'fire lane' through the car park and camp site allowing access for emergency vehicles. There will also be a 'production route' which will allow emergency vehicles direct access to the backstage compound.
9. All equipment will be PAT tested as per legal requirements.
10. Sports Care Services, event safety and medical support have been appointed as our medical team to deal with any injuries that may take place and to liaise with local authorities and emergency services.

d) The prevention of public nuisance

1. The site chosen is of reasonable distance from local dwellings as to prevent public nuisance via noise pollution.
2. The sound systems will be erected in such a way and be directed away from local dwellings.
3. Nico of NSP consulting is our designated noise consultant on the day, he will be monitoring noise levels in each tent to comply with regulations, amending amplifier levels accordingly. We won't have electronic sound limiting devices onsite for that reason. He will also be checking levels at the discussed sensitive properties on a regular basis during the night. Contact details for myself – Rhodri Shaw, Production manager – 07817 589 501 Nico – NSP – Noise consultant – 07879 695 533. Production manager phone will be in the production office at all times, therefore will be contactable at all times, production staff can then communicate messages via radio coms to relevant crew who will be wearing noise cancelling headsets.
4. Sufficient SIA licensed security will be on site to ensure the prevention of public nuisance. Nico of NSP will be carrying out db level tests and will keep a record of levels and the time taken. Monitoring points to be agreed at a site meeting.
5. All litter will be collected after the event and recycled where possible.
6. Noise levels will be measured in accordance with the Vanguardia report in order to avoid the risk of noise pollution and for the prevention of public nuisance.
7. All stage managers will be briefed along with each sound engineer as to the importance of our Noise Level engineer, Nico's input with regards to the level of sound on each stage. Nico will have the authority to demand lower levels at will.

e) The protection of children from harm.

1. There will be a strict 18+ policy on the entrance. Anyone found to look under the age of 21 will be asked to prove their age. Only a valid passport or driving licence will be accepted as proof of age.

**Annex 3 - Conditions attached after a hearing by the licensing authority/
Mediation meeting**

Mediation Meeting held between Eifion Roberts (Environmental Health Officer) and Rhodri Shaw (Applicant) on 19th March 2012 .

The following matters were agreed and are included as conditions:

Noise levels will be measured in accordance with the Vanguardia report in order to avoid the risk of noise pollution and for the prevention of public nuisance.

All stage managers will be briefed along with each sound engineer as to the importance of our Noise Level engineer, Nico's input with regards to the level of sound on each stage. Nico will have the authority to demand lower levels at will. As for the noise complaint last year, I believe it was during sound check around midday from the farm machine sale near Lovesgrove roundabout.

To avoid this happening again we will keep levels to a minimum until the sale has ended (around 2pm).

EVENT HEALTH & SAFETY RISK ASSESSMENT

Rev: 16 Feb 2012

Page 1 of 5



Site: The Rare One, Aberystwyth, 18 th - 20 th 2012 Operation: Erect, run & dismantle outside music event Location: Lovesgrove, Aberystwyth				Assessment No: RO/02 Date: 16.02.2012 Review Date: TBC		Prepared By: Don Sinclair Position: HSE Advisor Control supervised by: Rhodri Shaw (RS) Don Sinclair (DS)					
Estimated persons exposed: Event Personnel 20 Performers/Crew 40 Under 18's 0 Public (Event) 4000 Public (non-event) As applicable				Hazards with potential for harm Electricity ■ Security ■ Road Vehicles □ Power Supplies ■ Mobile plant/vehicles ■ Falls of material □ Fire/explosion ■ Overhead services ■ Deep excavations □ Noise/vibration ■ Flying particles □ Underground services ■ Demolition □ Fumes/gas ■ Uncontrolled collapse ■ Manual Handling ■ Water courses ■ Dust □ Contaminated material ■ Unstable vehicles ■ Falls from height ■ Heat □ Soft ground ■ Confined spaces □ Falls on level ■ Lifting operations ■ Poor lighting □ Adverse weather ■							
Notes: Likelihood of harm: High =3; Possible = 2; Unlikely = 1 Severity of harm: Major injury/death =3; Notifiable = 2; Minor injury = 1 Where residual risk is > 3 then a method statement is required. Where residual risk is > 5 then the HS&E Advisor to be contacted											
Other Risks (specify) (The above list is intended as a guide and is not exhaustive) Biological – Leptospirosis; Glass alcohol Late night arrival of punters											
1	2	3	4	5		6	7	8	9	10	
Hazard	Factors of harm		Risk	List Control Measures and reference method statement as applicable			Factors of harm		Residual risk	Control by	Additional Comments
	Likelihood	Severity	Multiple of cols 2 & 3				Likelihood	Severity	Multiple of cols 6&7	Initials of supervisor	
	See notes						See notes				
Electricity: Arising from generation and distribution of power to stage areas, site areas and bar area	3	3	9	Generators to arrive on site accompanied with all necessary statutory certification. All distribution cabling to be PAT tested and checked prior to use. Tail connections into generator and lighting dimmer racks to be undertaken by suitably qualified electrician and passed off as 'suitable and sufficient' Cable distribution routes to be located behind Heras type fencing and/or below cable matting. No cabling to be routed through public /traffic areas			1	3	3	RS/DS	All generating equipment to be earthed

EVENT HEALTH & SAFETY RISK ASSESSMENT

Rev: 16 Feb 2012

Page 2 of 5



Mobile plant and vehicles including:									
Hiabs, truck mounted lifting	2	3	6	Use of Hiabs and truck mounted lifting will be restricted to lifting off/on of generators, toilets and 1nr skip. The works will be undertaken by the suppliers during the 'build/dismantle' periods only when minimum personnel will be on site. Public areas will be afforded pedestrian routes	1	3	3	RS/DS	
Fork lift truck,	2	3	6	FLT operations will be restricted to back stage areas only during 'show times'. FLT operator to be suitably qualified	1	3	3	RS/DS	Working personnel to wear hi viz
Equipment delivery vehicles	2	3	6	All large deliveries will be undertaken prior to and post show time and will gain site access through a dedicated production gate. Vehicles will be directed by gate located traffic marshals	1	3	3	RS/DS	Pedestrian segregation to be provided as far as is reasonably practicable
Crew /Public Parking	2	6	6	All parking will be marshalled in dedicated parking areas. No vehicles will be allowed into the showground area once the public access gates have been opened.	1	3	3	RS/DS	
Vehicle access/exit into/from event areas	3	3	9	Public vehicle access to be marshalled through one way system. Provision of dedicated shuttle bus access gate, with segregated drop off and turning area. Sterile lane through the site to afford access for emergency vehicles Liaison with Police in case of traffic build up of highway	1	3	3	RS/DS	Provision of background & festoon lighting along pedestrian areas
Falls from height	2	3	6	Remote possibility when focussing lamps, and or working on stage deck otherwise no work at height foreseen. Suitable podiums, steps or working platforms will be utilised	1	3	3	RS/DS	No work requiring the use of harnesses will be permitted
Falls on level	2	2	4	All obstructions or protrusion from ground to be identified or removed particularly on pedestrian walkways Maintain housekeeping crew and remove risk obstructions immediately. Bar staff & security to ensure that personnel showing signs of excessive inebriation are refused service and/or removed from site .	1	2	2	RS/DS	Post notices informing that excessively, drunken people will be removed from site

Nearby water course & farm supplied water main	2	3	6	<p>Personnel access to nearby water course to be excluded as far as is reasonably practicable by means of Heras fencing</p> <p>Check quality of water for potable purposes and control access to supply by means of standpipe. If checks are not satisfactory consider utilising bowser of potable water.</p>	1	3	3	RS/DS	<p>Post signs on fence and where necessary warning of biological hazards</p>
Security including:									
Public Disorder	2	3	6	All security personnel to be suitably certified and whole site team to develop emergency response plan, by virtue of a pre-event briefing undertaken by the site manager.	1	3	3	RS/DS	
Over-subscription	2	3	6	Attendee numbers to be monitored through the box office. Production gate security to report to box office with regular updates of backstage numbers. Backstage numbers to be kept to a minimum to avoid uncontrolled overcrowding. Options to open tent sides if overcrowding of tents looks imminent.	1	3	3	RS/DS	Entry to site to be closed from 12 midnight to avoid late-night access and minimise suspected trouble makers
Unauthorised access to site	3	3	9	<p>All authorised personnel to be issued with identity wrist bands.</p> <p>Security to undertake regular perimeter checks for signs of security breaches.</p> <p>Highly visible security presence at gates and show ground, with security personnel being easily identifiable.</p>	1	2	2	RS/DS	
Security personnel fatigue	2	6	6	Security management must ensure that suitable working hours and breaks are afforded to security personnel.	1	2	2	Security Management	
Drunkenness and attendees bringing alcohol, drugs, weapons or glass receptacles into the show ground	3	3	9	<p>Security searches at main gates.</p> <p>Liaison with Police regarding drugs and/or weapons</p>				Security Management	Notices to be posted on main gates informing of reasons for refusal of entry into the site

EVENT HEALTH & SAFETY RISK ASSESSMENT

Rev: 16 Feb 2012

Page 4 of 5



<p>Lifting Operations Failure of lifting equipment Falls of components (see above) Overtuming of lifting equipment</p>	2	3	6	<p>Lifting operations are restricted to: a skip, generators, possibly the tent components and the toilets. All works will be undertaken by the suppliers by competent personnel. All equipment will be lifted on firm level ground</p>	1	3	3	RS/DS	
<p>Fire/Explosion arising from fuel in generators or electrical systems or smoking</p>	2	3	6	<p>Generators to be self bunded and brought to site full to avoid the need to refuel. All portable equipment to be PAT tested and installations to be undertaken by competent personnel only. All tents to be 'certified' as fire proof. Fire plan to be developed, including suitable provision of fire fighting equipment. Management briefing for all working personnel to ensure emergency evacuation protocols are known. Maintenance of sterile emergency vehicle site access at all times No smoking permitted in tents and/or public enclosed areas</p>	1	3	3	RS/DS	No smoking signs to be posted
<p>Uncontrolled Collapse of tents and/or stage decks</p>	2	3	6	<p>Tents to be erected on flat firm ground in strict accordance with manufacturer's instructions. Tent erection company to provide 'baby-sitters' to monitor condition of tents during show time. Decks to be erected on firm level ground, with strict safe working loads to be enforced at all times. Options to remove tent sides during adverse weather or in the event of maximum capacities being reached.</p>	1	3	3	RS/DS	Any alterations to tents or decks to be undertaken by suitably qualified personnel only
<p>Noise from PA's</p>	3	3	9	<p>All speakers to be pointed away from highway and contained within tents (as far as is reasonably practicable)</p>	1	3	3	RS/DS	Working personnel to be provided with suitable hearing protection

EVENT HEALTH & SAFETY RISK ASSESSMENT

Rev: 16 Feb 2012

Page 5 of 5



Fumes/gas from generators migrating into tents	3	3	9	Locate generators at suitable distances away from tents to eliminate this hazard	1	3	3	RS/DS	Note : Trailing cables to be matted where necessary
Manual handling	2	2	4	Maximise mechanical handling where possible. Any personnel involved in lifting should be suitably fit and competent	1	2	2	RS/DS	
Unstable vehicles	2	3	6	See above regarding stone hardstandings, access/egress routes and lifting operations	1	3	3	RS/DS	
Overhead Services	1	3	3	No overhead services in show area and all elements to be confined within show space	1	1	1	RS/DS	
Adverse weather	3	3	9	Emergency response to ensure integrity of tent structures during high winds	1	3	3	RS/DS	
Environmental	2	3	6	Generators to be self bunded and/or stood on drip trays. See comments above regarding location of speakers. All waste materials to be moved into one skip and removed from site. Event to comply as far as is reasonably practicable to the requirements of the Environmental protection Act.	1	3	3	RS/DS	
Biological/Contaminated material –Arising from the presence of livestock in the show ground and toilet provision	2	3	6	Removal of livestock from field 28 days prior to the event and clearing of faeces from fields as far as is reasonably practicable Discourage all personnel from urinating in hedges and to use toilets provided	1	2	2	RS/DS	Suitable controls on chemical toilets by supplier and supply of running water to wash hands
Power supplies	2	3	6	All power generated through supplier provided generators, cabling to be safely managed and installations by competent personnel only	1	3	3	RS/DS	

Design Note

To:	Rhodri Shaw	Date:	May 2011
Distribution:	As Required	File Ref:	VC-100918-AA-DN-0001
From:	Olly Creedy (Vanguardia)	Checked:	DP
Job No:	VC100918	Passed:	MM
Discipline/s:	Environmental Acoustics (EN)		
Job Title:	The Rare One, Aberystwyth		
Subject:	Offsite Noise Predictions		

1. Introduction

- 1.1. The purpose of this design note is to determine the offsite noise levels during the Rare One – live music event.
- 1.2. Guideline noise levels are provided in accordance with the code of practice on Environmental Noise Control at Concerts, and from similar past successful events.
- 1.3. Predictions are carried out in accordance with ISO 9613-2 "Attenuation of sound during propagation outdoors"

2. Guidance

- 2.1. For a rural one-off event the daytime noise levels shall not exceed $L_{Aeq,15}$ 65dB(A) between the hours of 0900 and 2300 at the nearest noise sensitive premises when measured over a 15 minute period.
- 2.2. Based on guidance from the World Health Organisation and BS8233:1999 the internal level for good resting/sleeping conditions shall be $L_{Aeq,1}$ 30dB(A). This equates to an external level between the hours of 2300 and 0900 of approximately $L_{Aeq,1}$ 45dB(A) through a partially open window. This has been proven to be a good indicator for a low number of noise complaints and has been used for a number of late night UK based events.

3. Predictions

- 3.1. The nearest noise sensitive locations have been identified as;
 - Capel Bangor – 1150m to the East of the site
 - Comins Coch / Waunfawr – 2800m to the West of the site

- 3.2. The nearest residential premises to the North of the site is Capel Dewi which is the other side of the valley. It is unlikely that during normal weather conditions that noise shall be an issue in this location.
- 3.3. The Table below provides predictions for Capel Bangor and Comins Coch/Waunfawr. The reference (mixer) levels for Tents 1 and 3 shall be at 8m from the PA and at 5m in the smaller Tent 2.

	Octave band Frequency (Hz)							dB(A)
	63	125	250	500	1K	2K	4K	
TENT 1 Mixer Level (dB) - FOH 8m	104	98	92	89	88	80	76	92.1
TENT 2 Mixer Level (dB) - centre of tent 5m	104	98	92	89	88	80	76	92.1
TENT 3 Mixer Level (dB) - FOH 8m	104	98	92	89	88	80	76	92.1
Capel Bangor (1150m)								
Tent Attenuation (dB)	0	1	2	3	4	5	5	-
Orientation Offset (dB)	1	2	3	4	5	6	6	-
Air Absorption (10 degrees C, 70% humidity)	0.1	0.5	1.2	2.2	4.3	11.2	37.7	-
Contribution From Tent 1 (dB)	59.7	51.4	42.7	36.7	31.6	14.7	0.0	40.8
Contribution From Tent 2 (dB)	55.7	47.3	38.6	32.6	27.5	10.6	0.0	36.7
Contribution From Tent 3 (dB)	59.7	51.4	42.7	36.7	31.6	14.7	0.0	40.8
CAPEL BANGOR TOTAL (dB)	63.5	55.2	46.5	40.4	35.4	18.5	0.0	44.5
Comins Coch / Waunfawr (2800m)								
Tent Attenuation (dB)	0	1	2	3	4	5	5	-
Orientation Offset (dB)	1	2	3	4	5	6	6	-
Air Absorption (10 degrees C, 70% humidity)	0.3	1.1	2.8	5.3	10.4	27.2	91.8	-
Contribution From Tent 1 (dB)	51.8	43.0	33.3	25.8	17.8	0.0	0.0	31.5
Contribution From Tent 2 (dB)	47.8	38.9	29.2	21.7	13.7	0.0	0.0	27.4
Contribution From Tent 3 (dB)	51.8	43.0	33.3	25.8	17.8	0.0	0.0	31.5
COMINS COCH TOTAL (dB)	55.6	46.8	37.1	29.6	21.5	0.0	0.0	35.2

Figure 3.1 – Predictions for nearest noise sensitive premises

- 3.4. Predictions indicate that in order to remain below the recommended night-time noise levels the maximum noise level at each reference location in the event arenas shall not exceed approximately $L_{Aeq,15}$ 92dB (A) over a 15 minute period.
- 3.5. Predictions indicate that during daytime hours the guideline noise levels are unlikely to be exceeded unless sound levels in excess of 110dB(A) are achieved at the reference location in each event arena.
- 3.6. Predictions are based on a temperature of 10 degrees C, and a humidity of 70% under normal meteorological conditions. Freak or extreme weather conditions may considerably affect the noise level predictions and cannot be forecast.

4. Recommendations

- 4.1. Before the event commences a sound check shall be carried out to determine a correlation between the on-site and off-site locations for the current weather conditions.

- 4.2. It is recommended that frequent measurements are carried out between the hours of 2300-0400 in each of the tents to ensure the average noise level does not exceed 92 dB(A) at the centre of each arena. This will not guarantee that the offsite levels are met and are only guidance.
- 4.3. It is also recommended that frequent measurements are made at the nearest noise sensitive premises to determine that the guideline conditions are met to minimise any noise complaints.
- 4.4. If any noise complaints are received then measurements shall be taken in the vicinity of the complaint to demonstrate that the conditions are met. If these are not, then on-site levels shall be reduced accordingly.
- 4.5. A communication method shall be setup between the production team and the local council to ensure any complaints are relayed back to the production team within a suitable timeframe.

Annex 4 – Plans



CLICK HERE to save up to 75% on reservations in over
52,000 hotels worldwide

Map of SN634811



Nearest transport link

Your notes

Tube:

Railway: Aberystwyth (3.04mi, 4.90km)



CLICK HERE to save up to 75% on reservations in over
52,000 hotels worldwide

Annex 4 – Plans

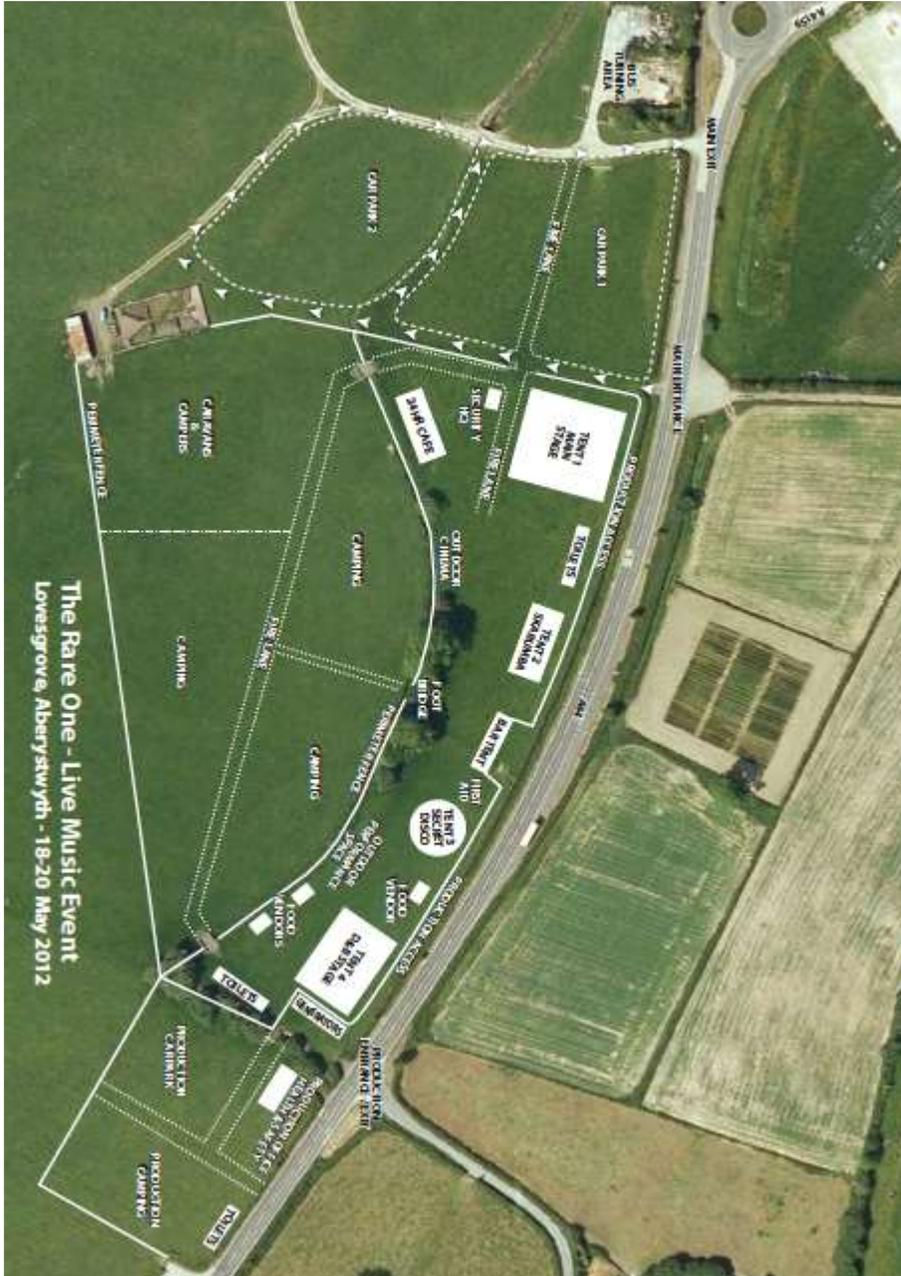

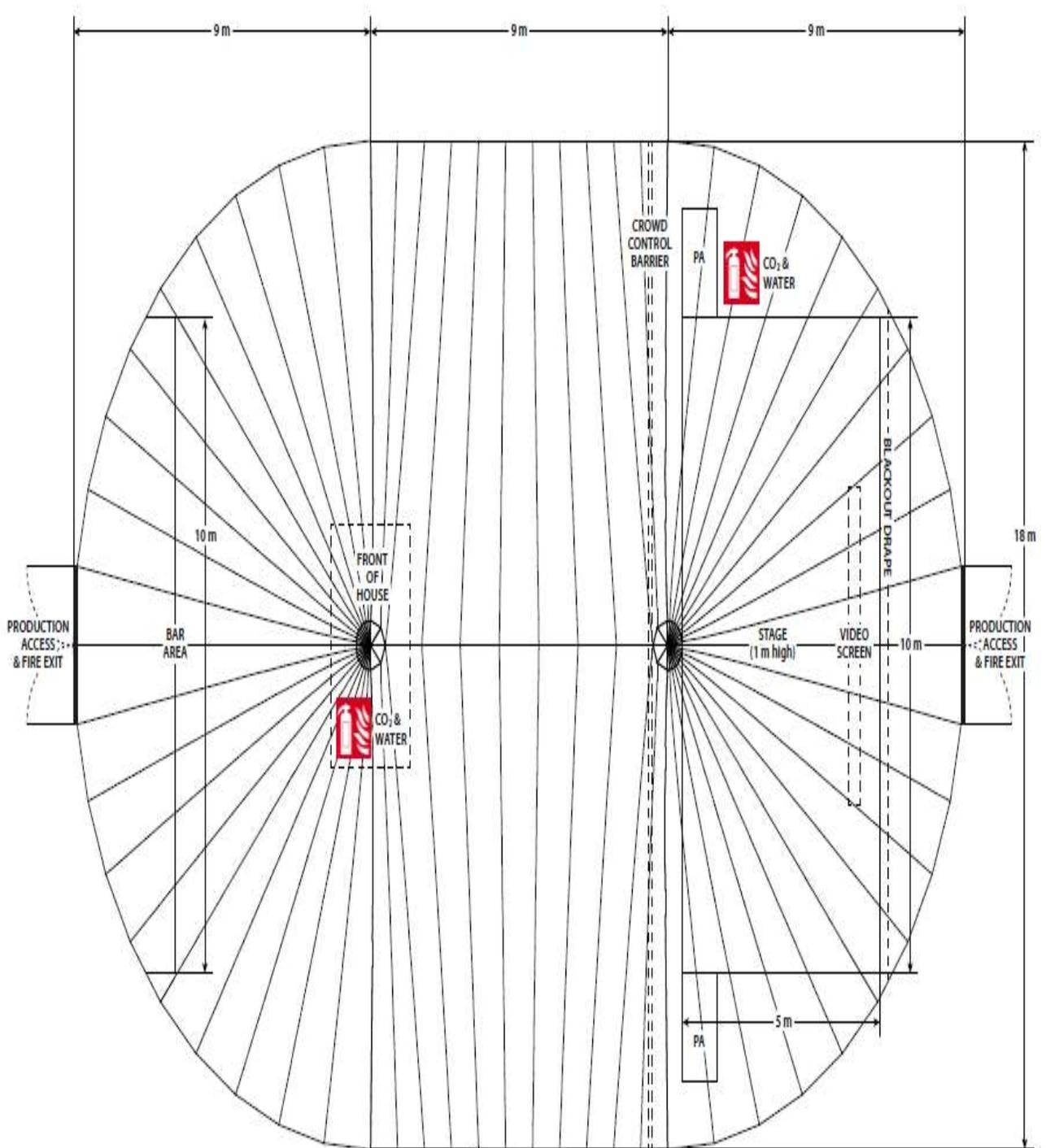

The Rare One - Live Music Event
 Lovesgrove, Aberystwyth - 18-20 May 2012



Tent One - Main Stage
 Standing Capacity - 860

ROUSTABOUT

TENT SPECIFICATIONS

Size	18m x 27m / 60ft x 90ft
Height	8m / 26ft
Sidewall Height	3m / 10ft
Area SQ M	430
Area SQ FT	4628
Standing Capacity	860
Seating Capacity	275
Space Required	84ft x 114ft

Colours Available

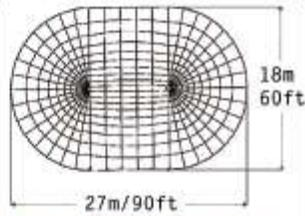
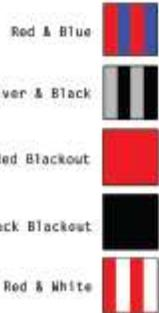

Frongoch Boat Yard, Smugglers Cove, Nr. Aberdovey, Gwynedd, LL35 0RS.
tel: 01654 767177 fax: 01654 767842 email: info@roustabout.info
www.roustabout.info

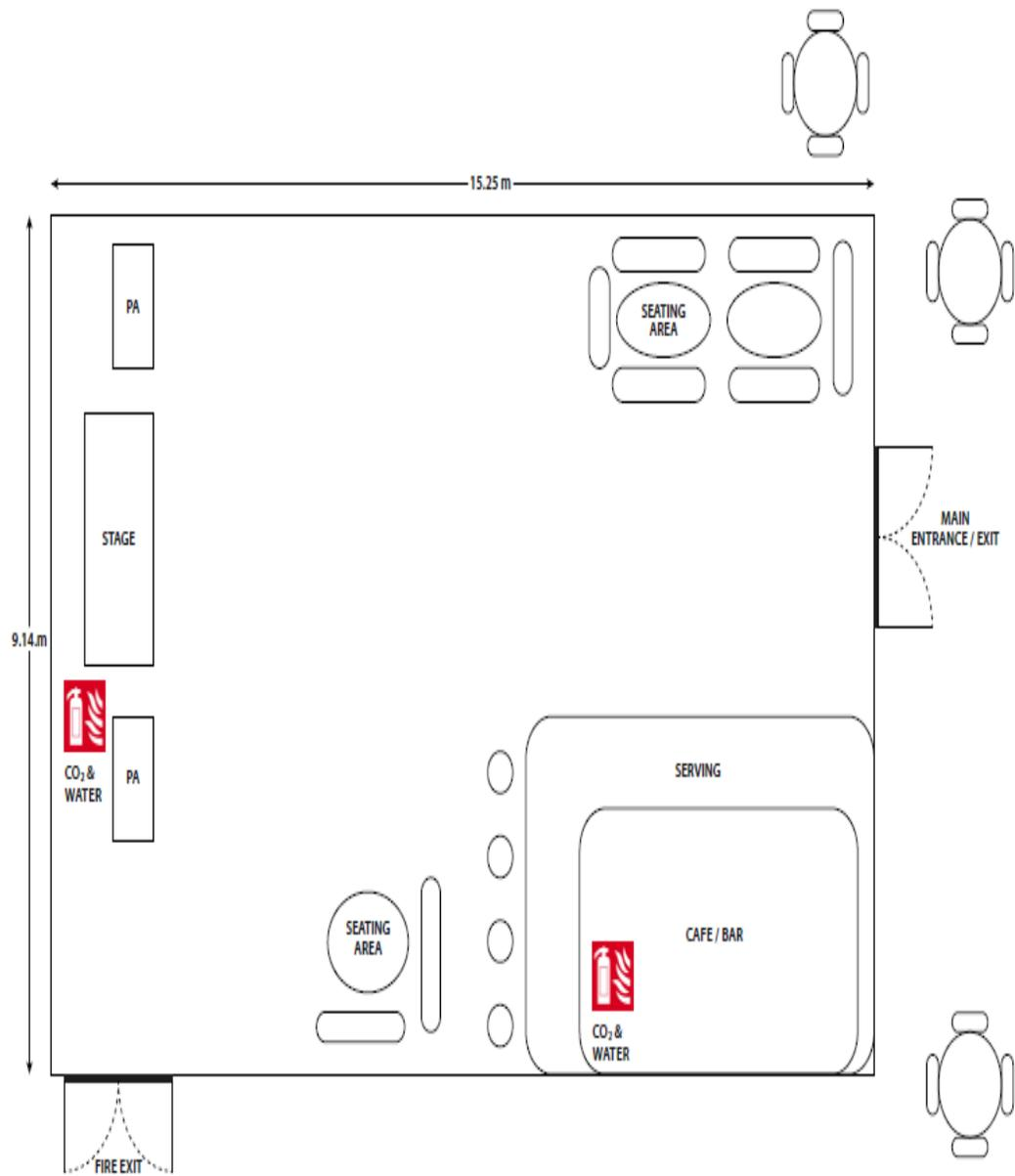

The Rare One - Live Music Event
 Lovesgrove, Aberystwyth - 18-20 May 2012

Tent Two - Skarumba
 Standing Capacity - 365

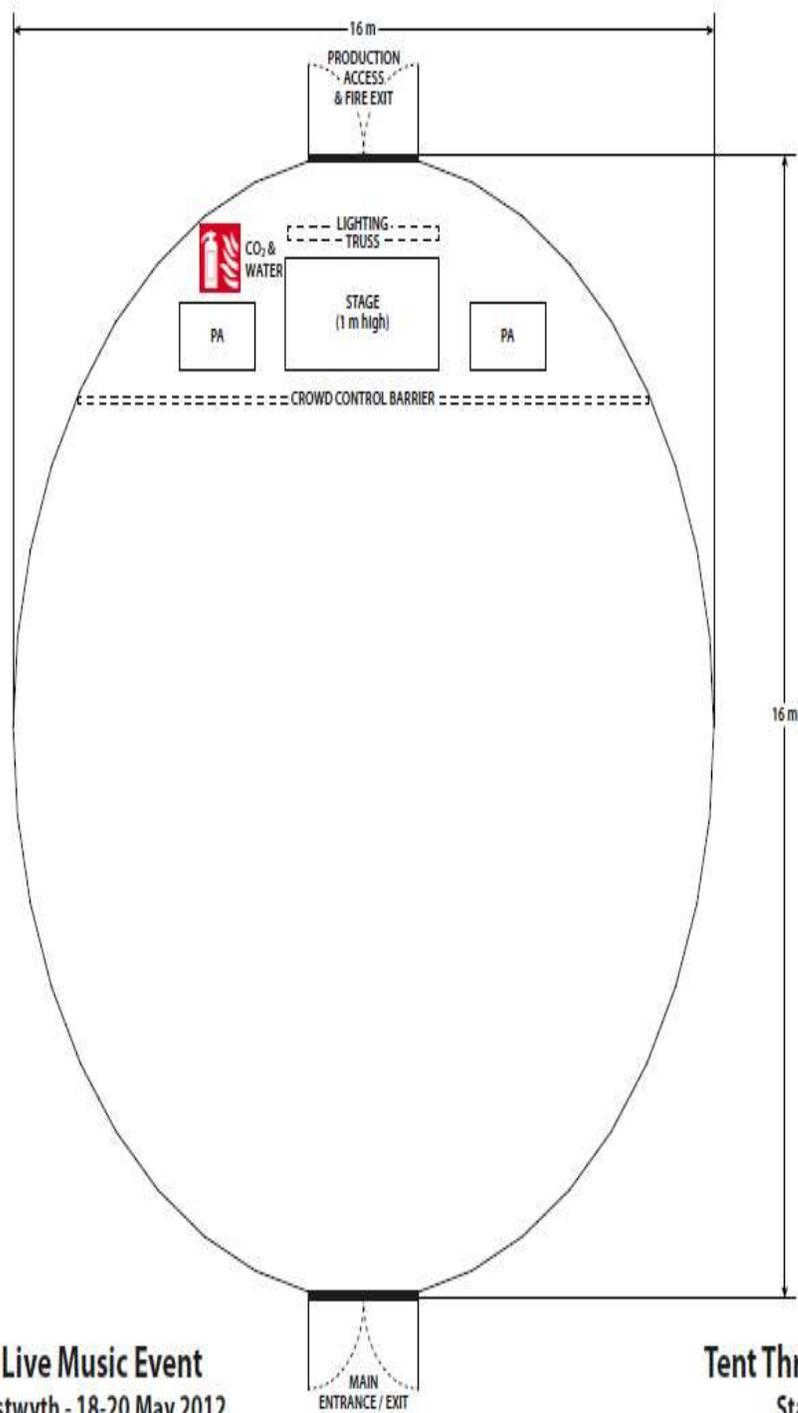

The Rare One - Live Music Event
 Lovesgrove, Aberystwyth - 18-20 May 2012

Tent Three - Secret Disco
 Standing Capacity - 365

ROUSTABOUT

TENT SPECIFICATIONS

Size	16m /50ft Round
Height	8m /26ft
Sidewall Height	2.4m /8ft
Area SQ M	182
Area SQ FT	1964
Standing Capacity	365
Seating Capacity	95
Space Required	74ft x 74ft

Colours Available

Blue & Pink Stars	
Pink & Purple	
Rainbow	
Yellow & White	
Red & White Dots	
Silver & Black	

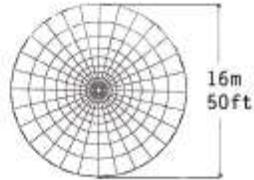

Fronnoch Boat Yard, Smugglers Cove, Nr. Aberdovey, Gwynedd, LL35 0RG.
tel: 01654 767177 fax: 01654 767842 email: info@roustabout.info
www.roustabout.info

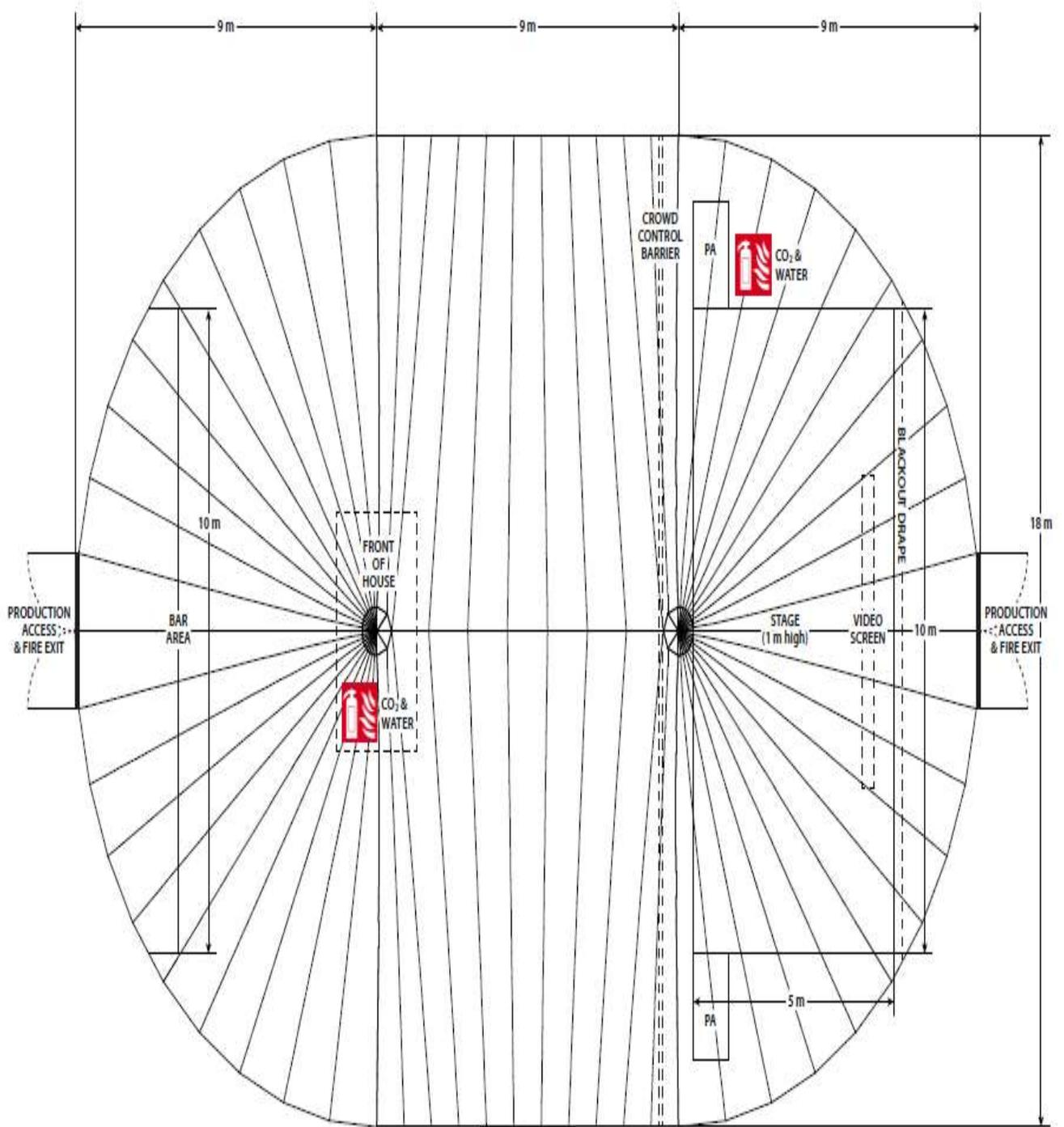

The Rare One - Live Music Event
 Lovesgrove, Aberystwyth - 18-20 May 2012



Tent Four - D&B Stage
 Standing Capacity - 860

